

# Consensus and Universal Construction

INF346, 2015

# So far...

Shared-memory communication:

- safe bits  $\Rightarrow$  multi-valued atomic registers
- atomic registers  $\Rightarrow$  atomic/immediate snapshot

# Today

Reaching **agreement** in shared memory:

- Consensus
  - ✓ Impossibility of wait-free consensus
- 1-resilient consensus impossibility
- Universal construction

# System model

- $N$  *asynchronous* (no bounds on relative speeds) processes  $p_0, \dots, p_{N-1}$  ( $N \geq 2$ ) communicate via atomic read-write registers
- Processes can fail by **crashing**
  - ✓ A crashed process takes only finitely many **steps** (reads and writes)
  - ✓ Up to  $t$  processes can crash:  **$t$ -resilient system**
  - ✓  $t=N-1$ : **wait-free**

# Consensus

Processes *propose* values and must *agree* on a common decision value so that the decided value is a proposed value of some process

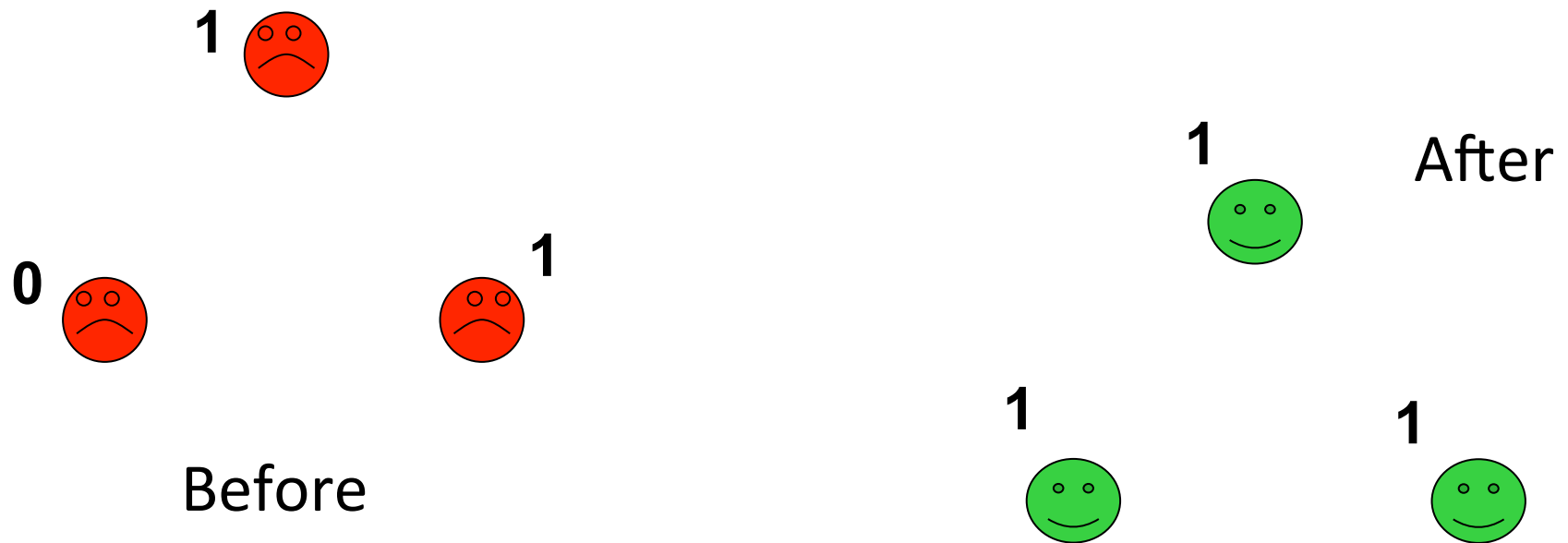

# Consensus: definition

A process *proposes* an *input* value in  $V$  ( $|V| \geq 2$ ) and tries to *decide* on an *output* value in  $V$

- *Agreement*: No two processes decide on different values
- *Validity*: Every decided value is a proposed value
- *Termination*: No process takes infinitely many steps without deciding  
(Every *correct* process decides)

# Optimistic (**0-resilient**) consensus

Consider the case  $t=0$ , no process fails

Shared: 1WNR register  $D$ , initially  $T$  (default value not in  $V$ )

Upon **propose**( $v$ ) by process  $p_i$ :

```
if  $i = 0$  then  $D.write(v)$            // if  $p_0$  decide on  $v$   
wait until  $D.read() \neq T$          // wait until  $p_0$  decides  
return  $D$ 
```

(every process decides on  $p_0$ 's input)

# Impossibility of wait-free consensus [FLP85,LA87]

**Theorem 1** No **wait-free** algorithm solves consensus

We give the proof for  $N=2$ , assuming that  
 $p_0$  proposes 0 and  $p_1$  proposes 1

Implies the claim for all  $N \geq 2$



# Proof of Theorem 1

- We show that no 2-process wait-free solution exists for **iterated** read-write memory:  $R_0[], R_1[]$
- Code for  $p_i$  in round  $r$ : write to  $R_i[r]$  and read  $R_{1-i}[r]$ :

```
r := 0
repeat
    r := r+1;
     $R_i[r].write(v_i)$ ;
     $v_i := R_{1-i}[r].read()$ ;
until not decided( $v_i$ )
```

(until the current state does not map to a decision)

- The iterated memory is **equivalent** to non-iterated one for **solving consensus**

# Proof of Theorem 1

Initially each  $p_i$  only knows its input

One round of IIS:

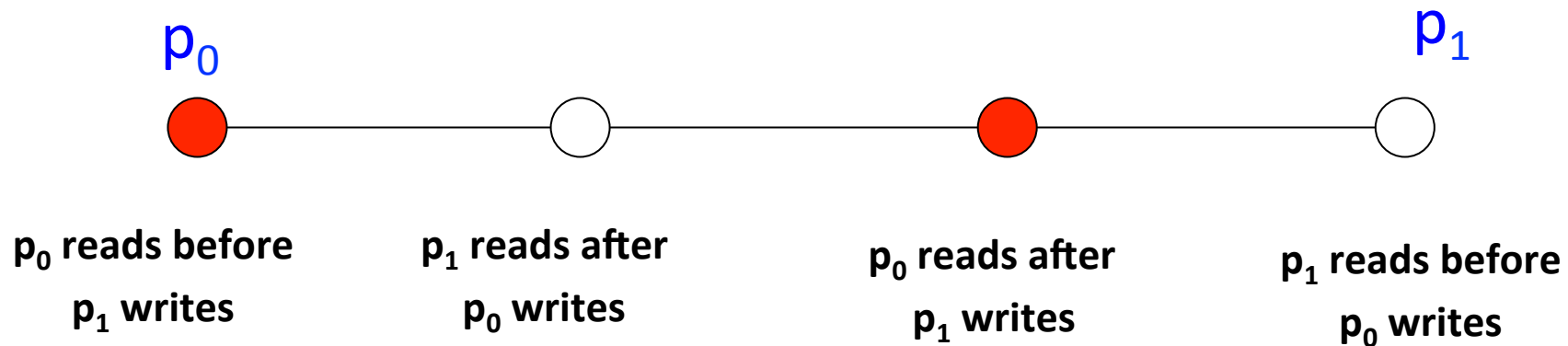

# Proof sketch for Theorem 1

Two rounds:

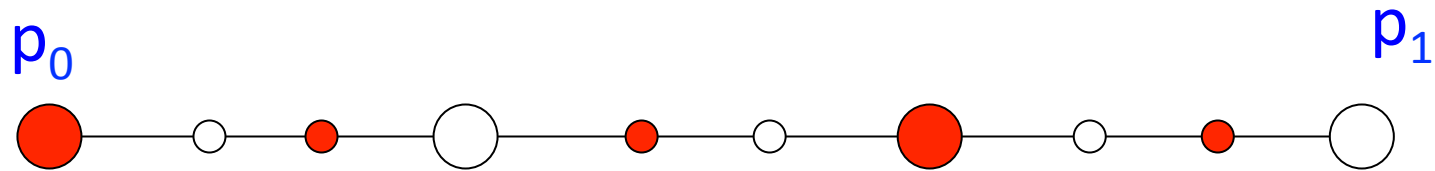

# Proof of Theorem 1

And so on...

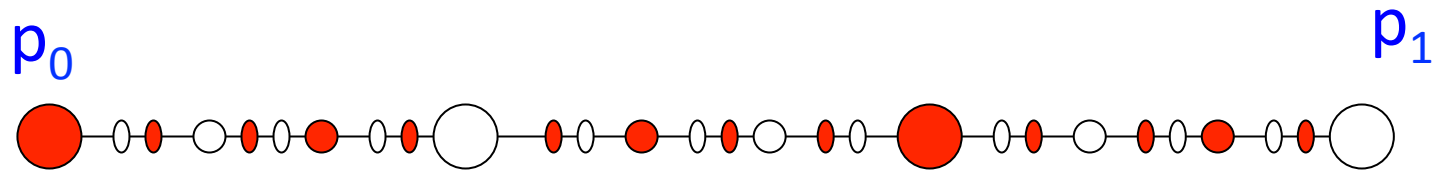

Solo runs remain connected - no way  
to decide!

# Proof of Theorem 1

Suppose  $p_i$  ( $i=0,1$ ) proposes  $i$

- $p_i$  must decide  $i$  in a solo run!

Suppose by round  $r$  every process decides

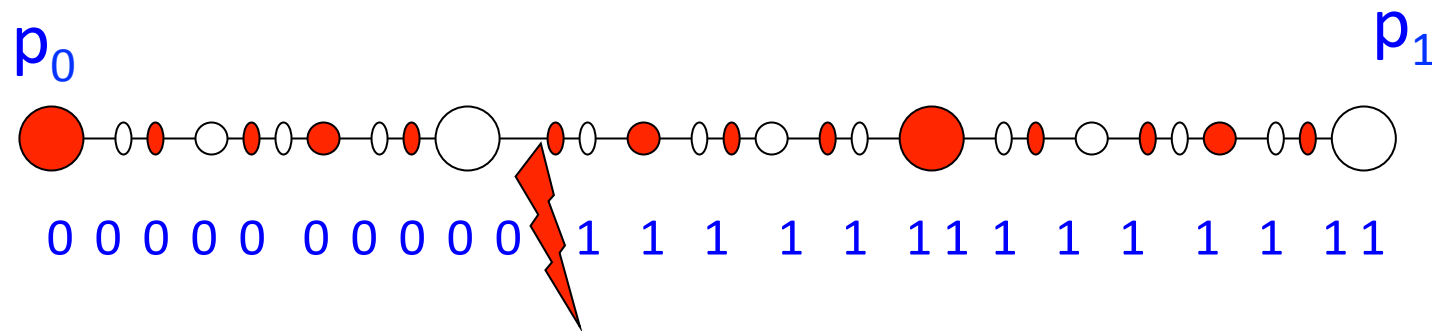

There exists a run with conflicting decisions!

# So...

- No algorithm can wait-free (N-resiliently) solve consensus
- We cannot tolerate N-1 failures: can we tolerate less?
  - ✓ E.g., can we solve consensus **1-resiliently**?

# 1-resilient consensus?

What if we have 1000000 processes and one of them can crash?

NO

We present a direct proof now  
(an indirect proof by reduction to the wait-free impossibility also exists)

## Impossibility of 1-resilient consensus [FLP85,LA87]

**Theorem 2** No 1-resilient (assuming that one process might fail) algorithm solves consensus in read-write

### Proof

By contradiction, suppose that an algorithm  $A$  solves 1-resilient binary consensus among  $p_0, \dots, p_{N-1}$



# Proof

A run of  $A$  is a sequence of atomic *steps* (reads or writes) applied to the initial state

A run of  $A$  can be seen as an initial *input configuration (one input per process)* and a sequence of process ids  $i_1, i_2, \dots, i_k, \dots$  (all registers are atomic)

*Every correct (taking sufficiently many steps) process decides!*

# Proof: valence

Let  $R$  be a finite run

- We say that  $R$  is  *$v$ -valent* (for  $v$  in  $\{0,1\}$ ) if  $v$  is decided in *every* infinite extension of  $R$
- We say that  $R$  is *bivalent* if  $R$  is neither 0-valent nor 1-valent  
(there exists a 0-valent extension of  $R$  and a 1-valent extension of  $R$ )

# Proof: valence claims

**Claim 1** Every finite run is 0-valent, or 1-valent, or bivalent.  
(by Termination)

**Claim 2** Any run in which some process decides  $v$  is  
 $v$ -valent  
(by Agreement)

**Corollary 1:** No process can decide in a bivalent run (by Agreement).

# Bivalent input

**Claim 3** There exists a bivalent input configuration (empty run)

## Proof

Suppose not

Consider sequence of input configurations  $C_0, \dots, C_N$ :

$C_i$ :  $p_0, \dots, p_{i-1}$  propose 1, and  $p_i, \dots, p_{N-1}$  propose 0

- All  $C_i$ 's are univalent
- $C_0$  is 0-valent (by Validity)
- $C_N$  is 1-valent (by Validity)

# Bivalent input

There exists  $i$  in  $\{0, \dots, N-2\}$  such that  $C_i$  is 0-valent and  $C_{i+1}$  is 1-valent!

$C_i$  and  $C_{i+1}$  differ **only in the input value of  $p_i$**  (it proposes 1 in  $C_i$  and 0 in  $C_{i+1}$ )

Consider a run  $R$  starting from  $C_i$  in which  $p_i$  takes no steps (crashes initially): eventually all other processes decide 0

Consider  $R'$  that is like  $R$  except that it starts from  $C_{i+1}$

- $R$  and  $R'$  are **indistinguishable!**
- Thus, every process decides 0 in  $R'$  --- contradiction ( $C_{i+1}$  is 1-valent)

# Critical run

**Claim 4** There exists a finite run  $R$  and two processes  $p_i$  and  $p_j$  such that  $R.i$  is 0-valent and  $R.j.i$  is 1-valent (or vice versa)

( $R$  is called **critical**)

**Proof of Claim 4:** By construction, take the bivalent empty run  $C$  (by Claim 3 it exists)

We construct an ever-extending fair (giving each process enough steps) run which results in  $R$

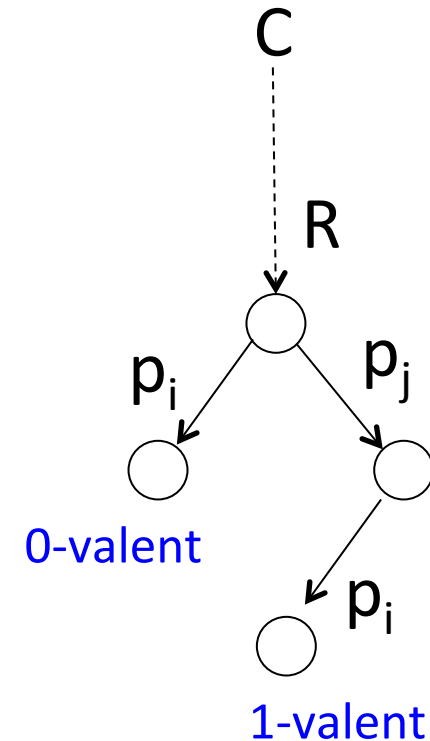

# Proof of Claim 4: critical run

**repeat forever**

take the **next** process  $p_i$  (in **round-robin** fashion)

**if** for some  $R'$ , an extension of  $R$ ,  $R'.i$  is  
bivalent **then**  $R := R'.i$

**else** stop

- If never stops – ever extending (infinite)  
bivalent runs in which every process is correct  
(takes infinitely many steps – contradiction  
with termination)
- If stops – (suppose  $R.i$  is 0-valent) – consider  
a 1-valent extension
  - ✓ There is a critical configuration between  $R$  and  $R'$

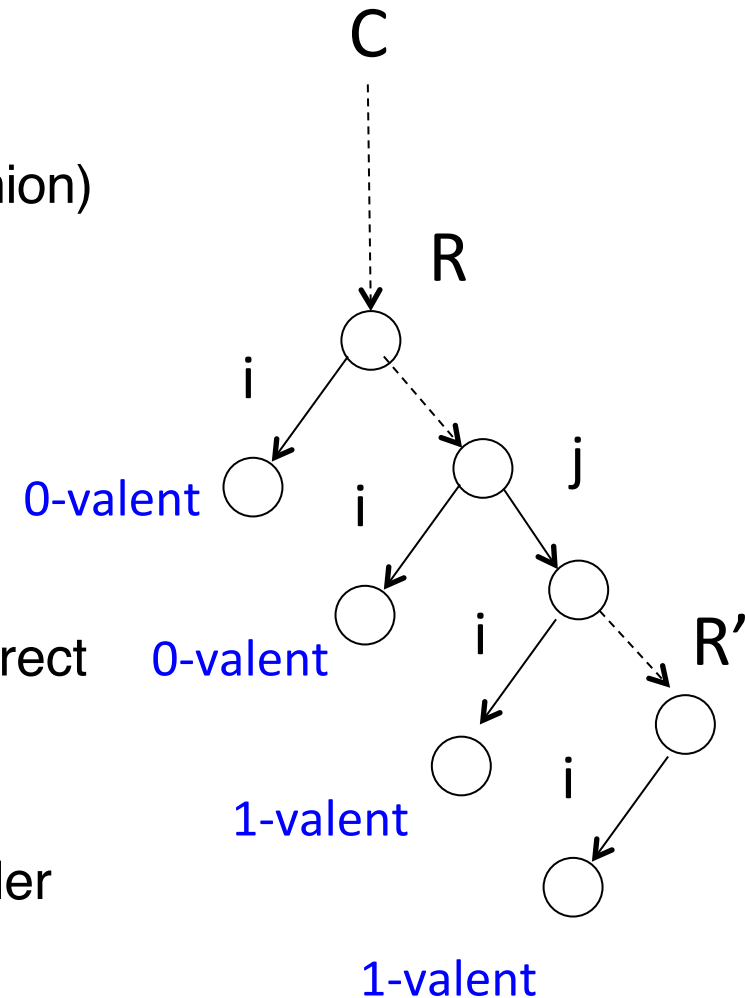

# Proof (contd.)

Take a critical run  $R$  (exists by Claim 4) such that:

- $R.0$  is 0-valent
- $R.1.0$  is 1-valent

(without loss of generality, we can always rename processes or inputs appropriately 😊)



## Proof (contd.): the next steps in R

Four cases, depending on the next steps of  $p_0$  and  $p_1$  in R

- $p_0$  and  $p_1$  are about to access different objects in R
- $p_1$  reads  $X$  and  $p_0$  reads  $X$
- $p_0$  writes in  $X$
- $p_1$  reads  $X$

# Proof (contd.): cases and contradiction

- $p_0$  and  $p_1$  are about to access **different** objects in  $R$ 
  - ✓  $R.0.1$  and  $R.1.0$  are indistinguishable

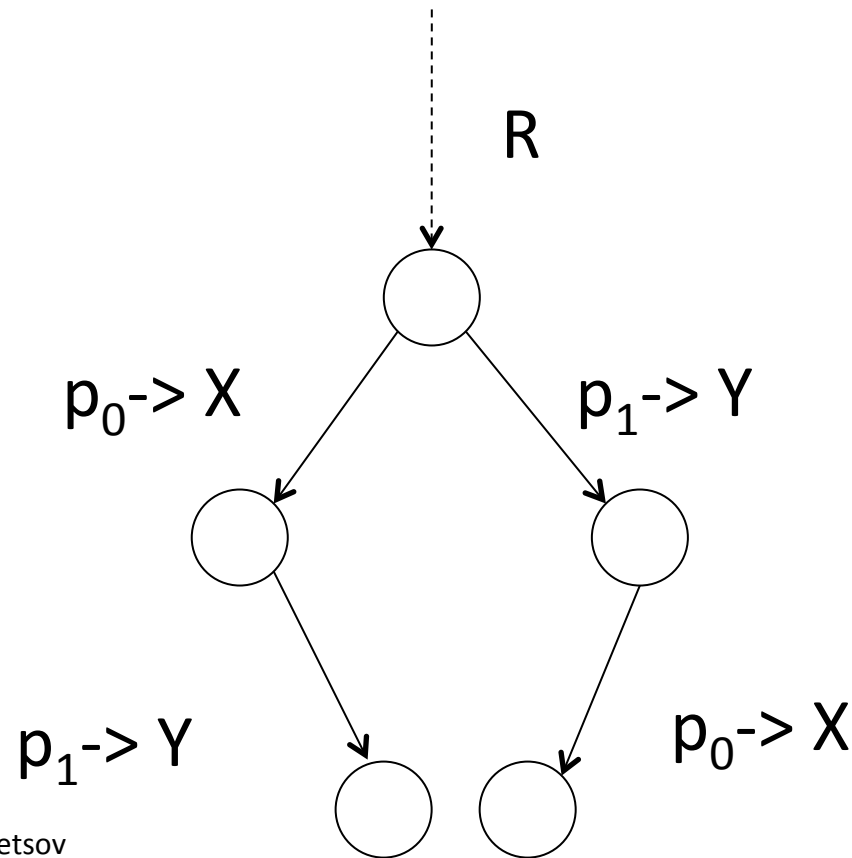

## Proof (contd.): cases and contradiction

- $p_0$  and  $p_1$  are about to **read** the same object  $X$   
R.0.1 and R.1.0 are indistinguishable

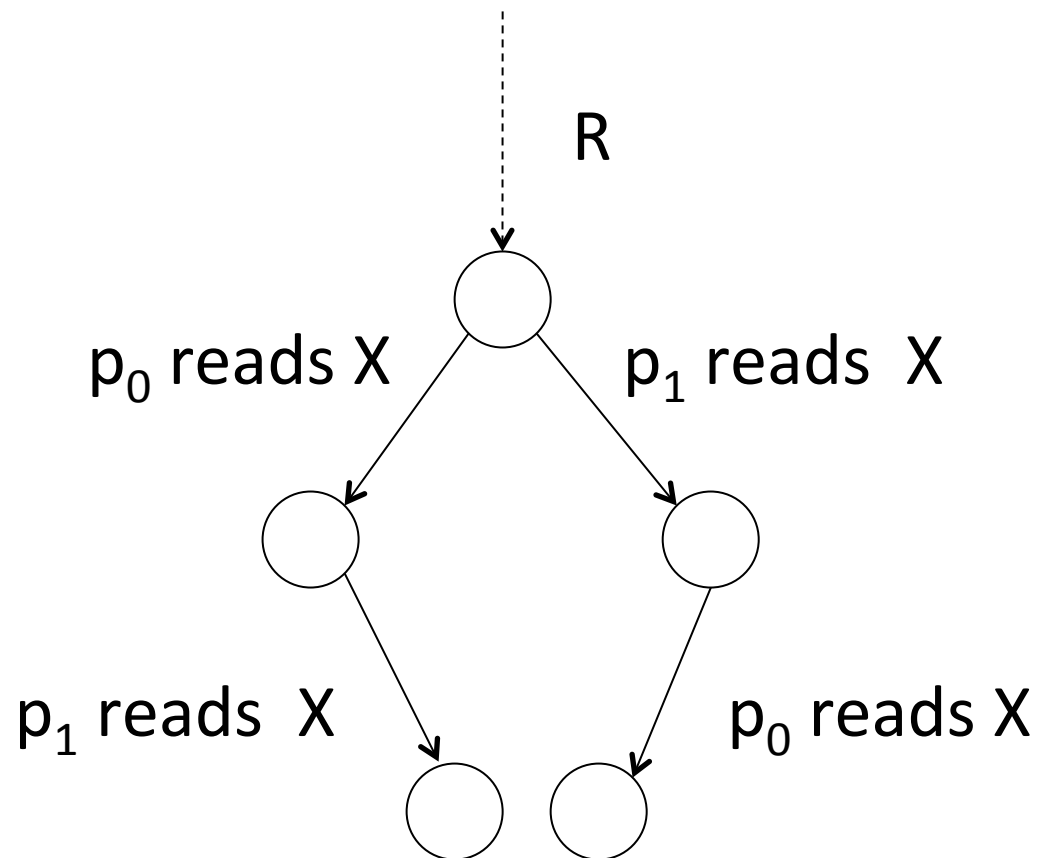

# Proof (contd.): cases and contradiction

- $p_0$  is about to write to  $X$ 
  - ✓ Extensions of R.0 and R.1.0 are indistinguishable for all except  $p_1$  (assuming  $p_1$  takes no more steps)

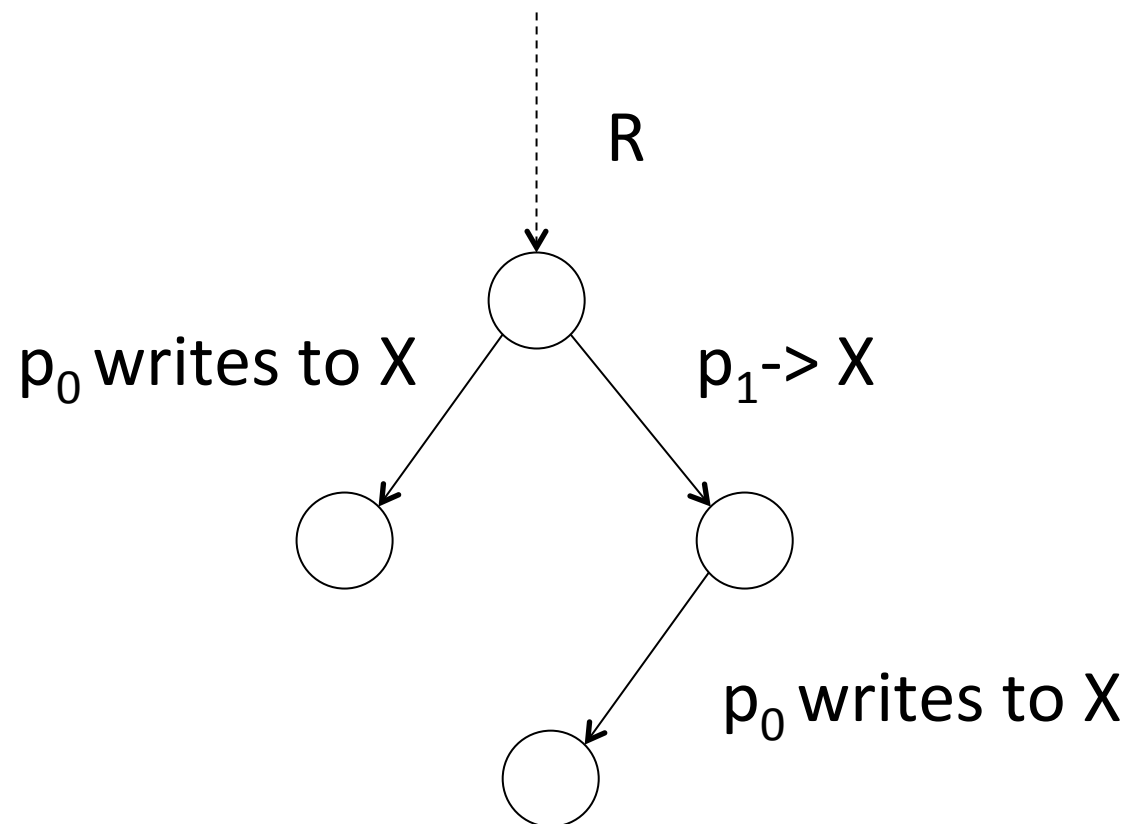

# Proof (contd.): cases and contradiction

- $p_0$  is about to read to  $X$ 
  - ✓ Extensions of R.0.1 and R.1.0 are indistinguishable for all but  $p_0$  (assuming  $p_0$  takes no more steps)

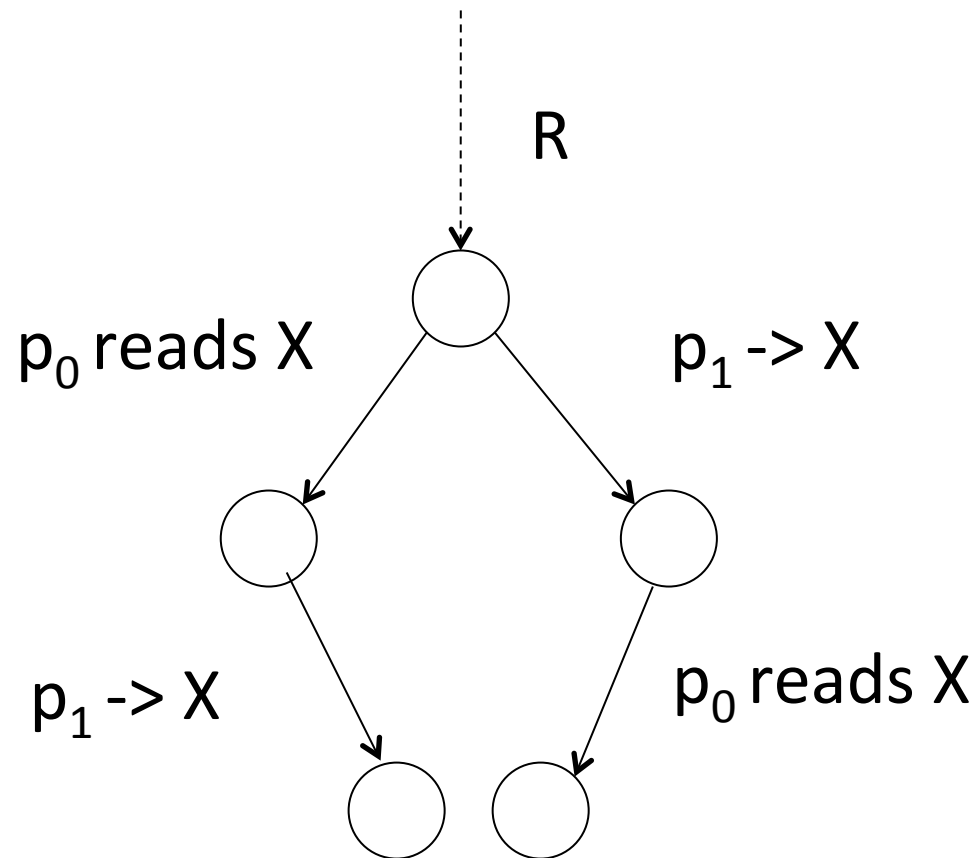

# Thus

- No critical run exists
- A contradiction with **Claim 4**

⇒ 1-resilient consensus is impossible **in read-write**

# Next

- Combining registers with stronger objects
  - ✓ Consensus and **test-and-set** (T&S)
  - ✓ Consensus and **queues**
- **Universality** of consensus
  - ✓ Consensus can be used to implement any object

# Test&Set atomic objects

Exports one operation `test&set()` that returns a value in  $\{0,1\}$

**Sequential specification:**

The first atomic operation on a T&S object returns 0, all other operations return 1



# 2-process consensus with T&S

## Shared objects:

T&S TS

Atomic registers  $R[0]$  and  $R[1]$

## Upon propose( $v$ ) by process $p_i$ ( $i=0,1$ ):

$R[i] := v$

if  $TS.test\&set()=0$  then

    return  $R[i]$

else

    return  $R[1-i]$

# FIFO Queues

Exports two operations enqueue() and dequeue()

- enqueue(v) adds v to the end of the queue
- dequeue() returns the first element in the queue  
(LIFO queue returns the last element)

# 2-process consensus with queues

## Shared:

Queue Q, initialized (winner, loser)

Atomic registers R[0] and R[1]

## Upon propose(v) by process $p_i$ ( $i=0,1$ ):

R[i] := v

if Q.dequeue()=winner then

    return R[i]

else

    return R[1-i]

# But why consensus is interesting?

Because it is universal!

- If we can solve consensus among  $N$  processes, then we can *implement* any object shared by  $N$  processes
  - ✓ T&S and queues are universal for 2 processes
- A key to implement a generic fault-tolerant service (**replicated state machine**)

# What is an *object* ?

Object  $O$  is defined by the tuple  $(Q, O, R, \sigma)$ :

- Set of **states**  $Q$
- Set of **operations**  $O$
- Set of **outputs**  $R$
- **Sequential specification**  $\sigma$ , a subset of  $O \times Q \times R \times Q$ :
  - ✓  $(o, q, r, q')$  is in  $\sigma \Leftrightarrow$  if operation  $o$  is applied to an object in state  $q$ , then the object *can* return  $r$  and change its state to  $q'$
  - ✓ **Total** on  $O \times Q$  (defined for all  $o$  and  $q$ )

# Deterministic objects

- An operation applied to a *deterministic* object results in exactly one (output, state) in  $R \times Q$ , i.e.,  $\sigma$  can be seen a function  $O \times Q \rightarrow R \times Q$
- E.g., queues, counters, T&S are deterministic
- Unordered set (put/get) – non-deterministic

# Example: queue

Let  $V$  be the set of possible elements of the queue

$Q=V^*$  (all sequences with elements in  $V$ )

$O=\{\text{enq}(v)_{v \text{ in } V}, \text{deq}()\}$

$R=V \cup \{\emptyset\} \cup \{\text{ok}\}$

$\sigma(\text{enq}(v), q)=(\text{ok}, q.v)$

$\sigma(\text{deq}(), v.q)=(v, q)$

$\sigma(\text{deq}(), \emptyset)=(\emptyset, \emptyset)$

# Implementation: definition

A distributed algorithm  $A$  that, for each operation  $o$  in  $O$  and for every  $p_i$ , describes a **concurrent procedure**  $o_i$  using base objects

A run of  $A$  is *well-formed* if no process invokes a new operation on the implemented object before returning from the old one (we only consider well-formed runs)



# Implementation: correctness

A (wait-free) implementation  $A$  is correct if in every well-formed run of  $A$

- **Wait-freedom**: every operation run by  $p_i$  returns in a **finite number** of steps of  $p_i$
- **Linearizability**  $\approx$  operations “**appear**” instantaneous (the corresponding *history* is *linearizable*)

# Linearization

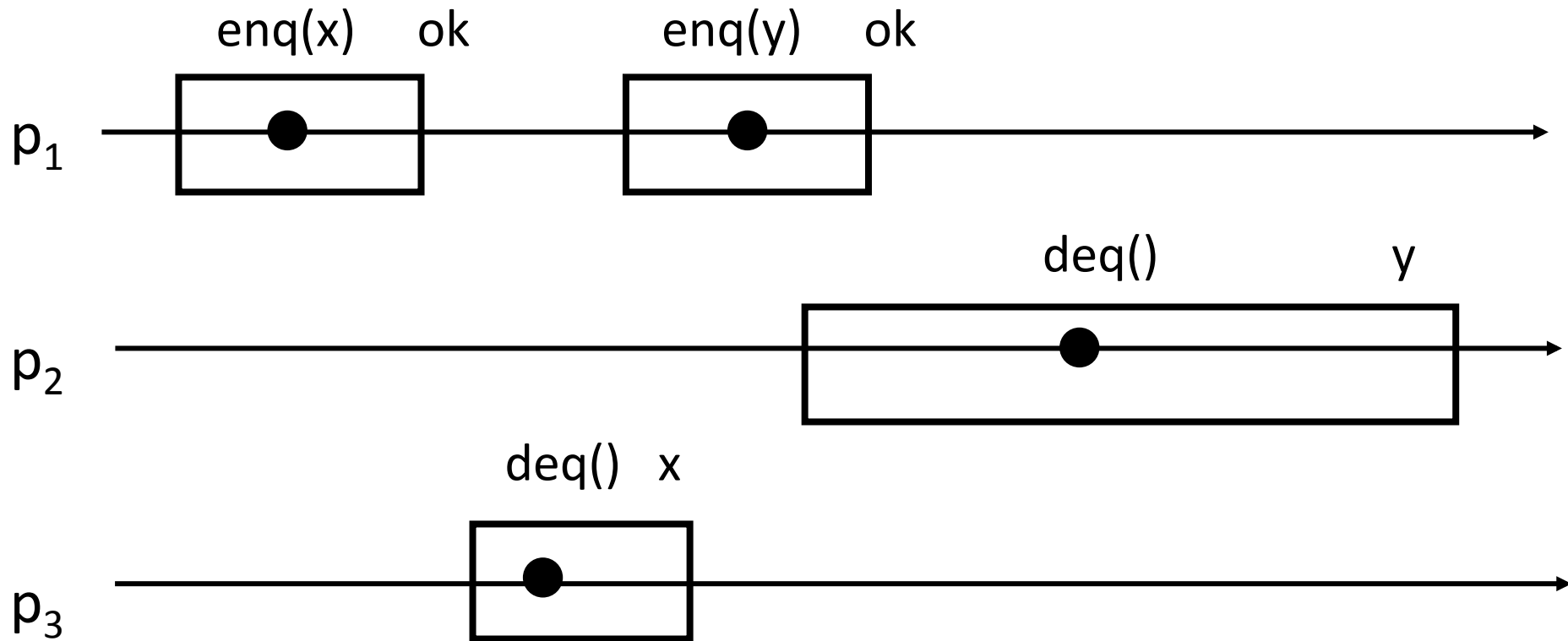

$p_1$ -enq(x);  $p_1$ -ok;  $p_3$ -deq();  $p_3$ -x;  
 $p_1$ -enq(y);  $p_1$ -ok;  $p_2$ -dequeue();  $p_2$ -y

# Universal construction

**Theorem 1** [Herlihy, 1991] If  $N$  processes can solve consensus, then  $N$  processes can (wait-free) implement every object  $O=(Q,O,R,\sigma)$

Suppose you are given an unbounded number of **consensus objects** and atomic read-write registers

You want to implement an object  $O=(Q,O,R,\sigma)$

How would you do it?

# Universal construction: idea

Every process that has a pending operation does the following:

- Publish the corresponding *request*
- Collect published requests and use consensus instances to **serialize** them: the processes agree on the order in which the requests are executed
- Processes agree on the **order** in which the published requests are executed

# Universal construction: variables

Shared abstractions:

N atomic registers  $R[0, \dots, N-1]$ , initially  $\emptyset$

N-process consensus instances  $C[1], C[2], \dots$

Local variables for each process  $p_i$ :

integer  $seq$ , initially 0

// the number of  $p_i$ 's requests executed so far

integer  $k$ , initially 0

// the number of **batches** of

// all requests executed so far

sequence  $linearized$ , initially empty

//the **serial order** of executed requests

# Universal construction: algorithm

Code for each process  $p_i$ : implementation of operation  $op$

```
seq++
R[i] := (op,i,seq)           // publish the request
repeat
    V := read R[0,...,N-1]    // collect all requests
    requests := V-{\linearized} //choose not yet linearized requests
    if requests $\neq\emptyset$  then
        k++
        decided:=C[k].propose(requests)
        linearized := linearized.decided
        //append decided request in some deterministic order
until (op,i,seq) is in linearized
return the result of (op,i,seq) in linearized
// using the sequential specification  $\sigma$ 
```

# Universal construction: correctness

- Linearization of a given run: the order in which operations are put in the *linearized list*
  - ✓ **Agreement** of consensus: all *linearized* lists are related by containment (one is a prefix of the other)
- Real-time order: if op1 precedes op2, then op2 cannot be linearized before op1
  - ✓ **Validity** of consensus: a value cannot be decided unless it was previously proposed



# Universal construction: correctness

- Wait-freedom:
  - ✓ **Termination** and **validity** of consensus: there exists  $k$  such that the request of  $p_i$  gets into *req* list of every processes that runs  $C[k].propose(req)$

# Another universal abstraction: CAS

Compare&Swap (CAS) stores a *value* and exports operation  $CAS(u,v)$  such that:

- If the current value is  $u$ ,  $CAS(u,v)$  replaces it with  $v$  and returns  $u$
- Otherwise,  $CAS(u,v)$  returns the current value

*A variation:* CAS returns a **boolean** (whether the replacement took place) and an additional operation  $read()$  returns the value

# N-process consensus with CAS

Shared objects:

CAS CS initialized  $\emptyset$

//  $\emptyset$  cannot be an input value

Code for each process  $p_i$  ( $i=0, \dots, N-1$ ):

$v_i :=$  input value of  $p_i$

$v :=$  CS.CAS( $\emptyset, v_i$ )

if  $v = \emptyset$

    return  $v_i$

else

    return  $v$

# Quiz: consensus power

Show that T&S has **consensus power at most 2**, i.e., it cannot be, combined with atomic registers, used to solve 3-process consensus

Possible outline:

- Consider the *critical bivalent* run  $R$  of  $A$ : every one-step extension of  $R$  is univalent (show first that it exists)
- Show that all steps enabled at  $R$  are on the same T&S object
- Show that there are two extensions of opposite valences that some process cannot distinguish