

TELECOM
ParisTech



Institut
Mines-Telecom

Electronique pour la conception des systèmes embarqués

Chadi Jabbour

SE748 / SE208



What is an embedded system?

An embedded system:

- ▶ is a computer based system
- ▶ is designed for a specific function or for several specific functions
- ▶ is embedded in a larger mechanical or electrical system
- ▶ is driven by and must respond to real world events

What is an embedded system?

Focus of SE748

An embedded system is driven by and must respond to real world events

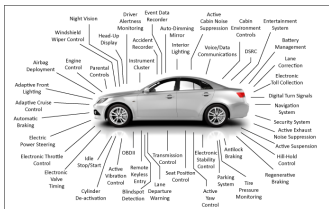

Basic sensors and data Acquisition
Integration and Operation: DLR-FB

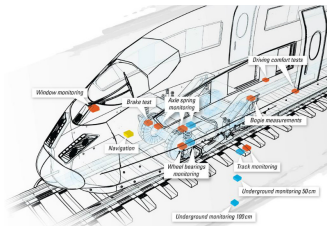
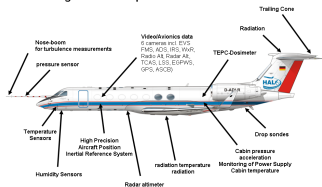

Increasing number of electronic devices in transport

Example 1: Assisted Parking system

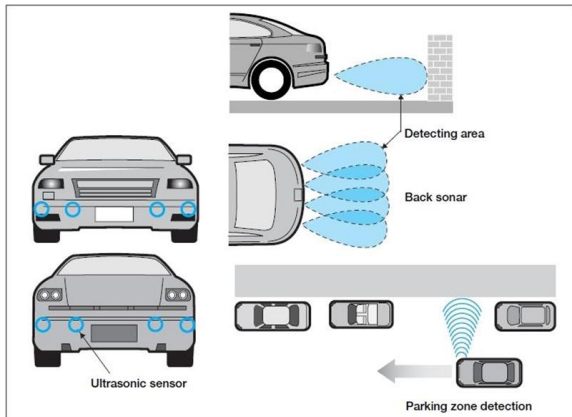

Parking systems use ultrasonic sensors to calculate the distance between the car and the obstacles

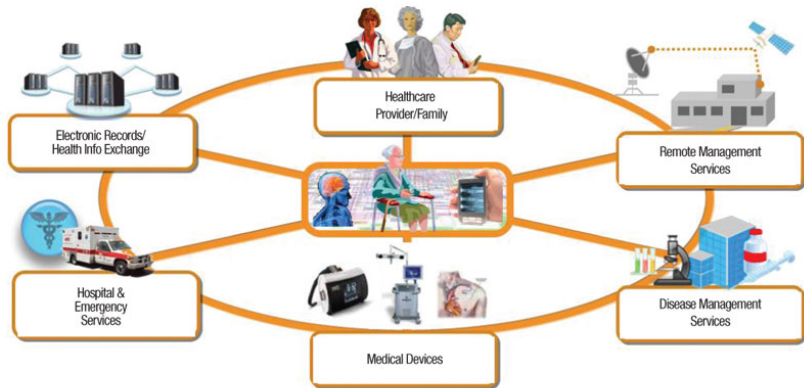

Electronic systems are massively used in medical applications today and this trend will accelerate in the near future

Example 2: Cardiac implant

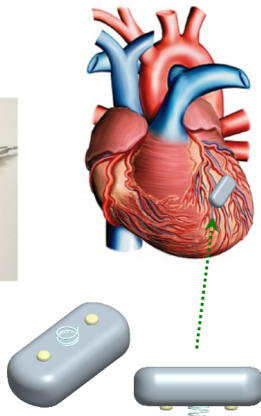
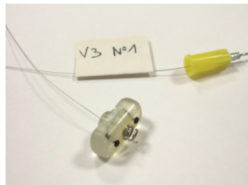

Collaboration TPT-Livanova

Design of several communicating cardiac sensors to help the operation of the pacemaker

Professional applications

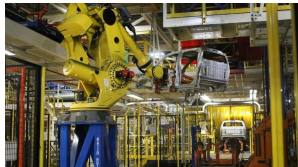
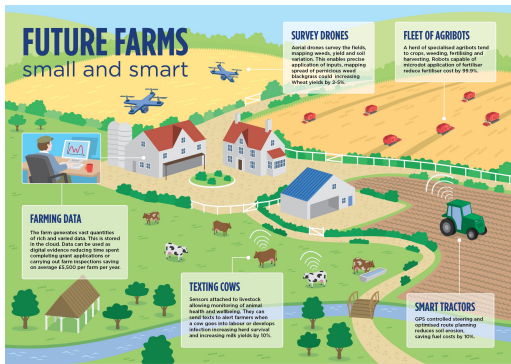

Embedded systems are widely used for improving the production in professional applications such as Industry, Agriculture & Construction

Example 3: Irrigation system

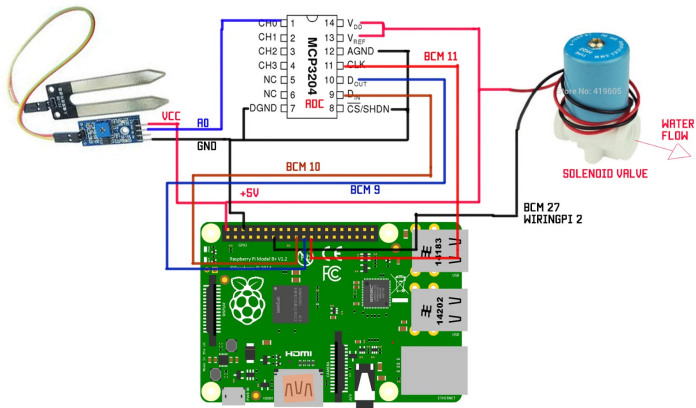

Irrigation system based on Arduino

The Arduino monitors the water level thanks to the moist sensor and enables the solenoid valve when it detects a water shortage

Consumer electronics and Appliances

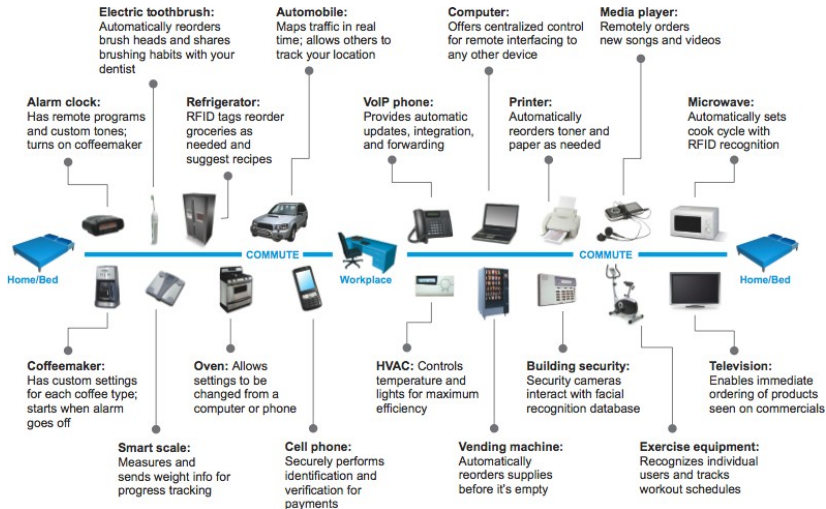

Example 4 : Microwave

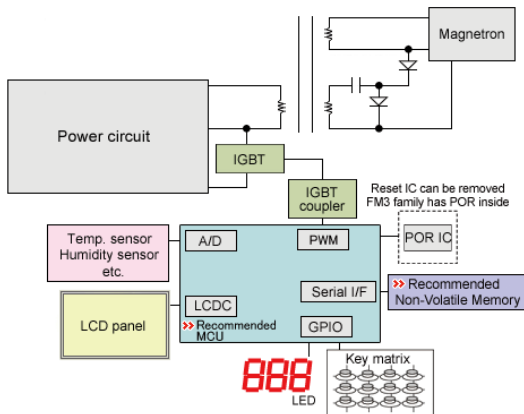

Microwave embedded system

Even in a simple microwave, the electronic circuitry is somehow complex with a high number of interfaces.



Despite the small volume, embedded systems for aerospace are highly needed and various:

- ▶ Launchers
- ▶ Communications and observations satellites
- ▶ Rovers

Example 5: Aerospace Observations

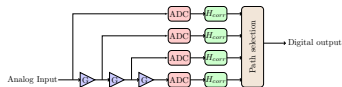
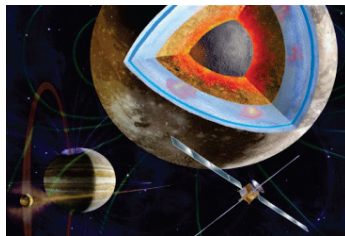
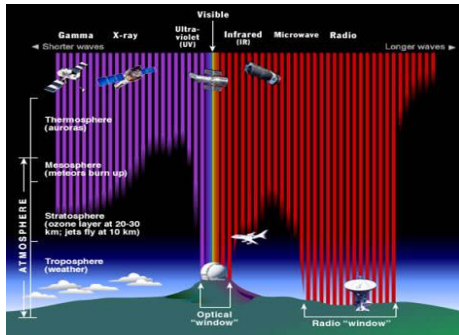

Juice mission

Explore the moons of Jupiter - Launch in 2022 from la Guyane

Collaboration TPT-LESIA on Radio receiver

Project STAR - 100 MHz bandwidth 120 dB Dynamic Range receiver

Interface with the real world

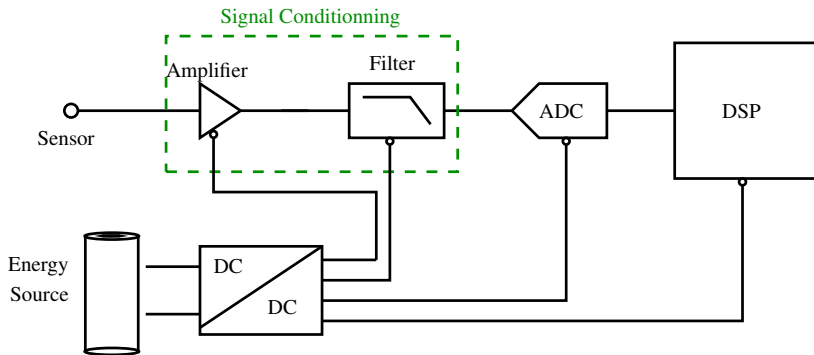

- ▶ Antennas
- ▶ Accelerometer
- ▶ Ultra-sound sensor
- ▶ Temperature sensors
- ▶ Humidity sensor
- ▶ Magnetic field sensors (Hall effect ...)
- ▶ Photodiode (Camera)
- ▶ Tactile sensor
- ▶ Proximity sensor
- ▶ ...

Amplifier

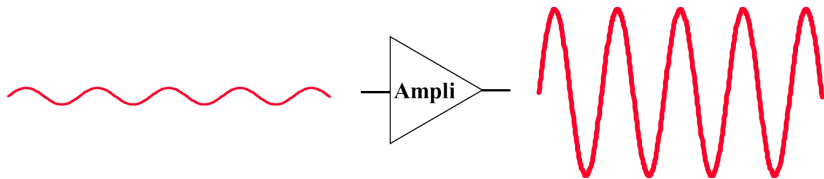

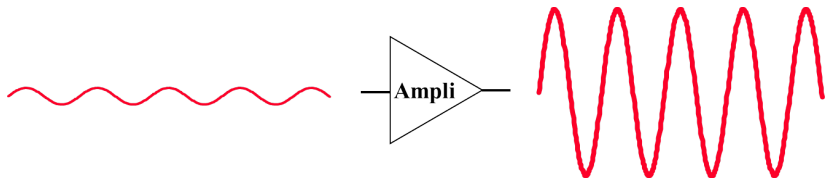

► Gain

Amplifier

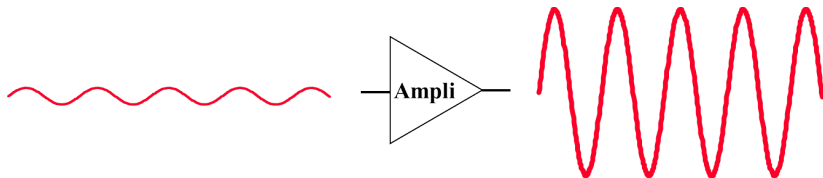

- ▶ Gain
- ▶ Noise

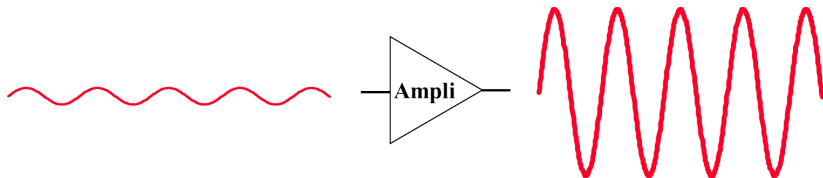

- ▶ Gain
- ▶ Noise
- ▶ Bandwidth

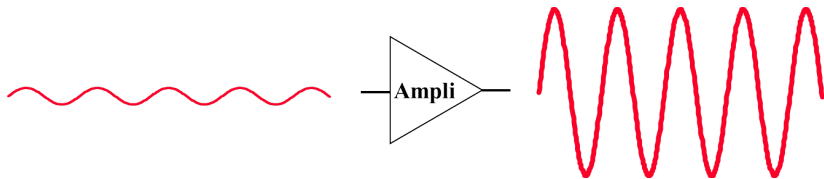

- ▶ Gain
- ▶ Noise
- ▶ Bandwidth
- ▶ Non-linearity

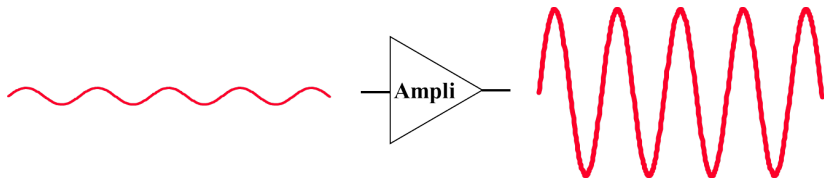

- ▶ Gain
 - ▶ Noise
 - ▶ Bandwidth
 - ▶ Non-linearity
- ▶ Input range

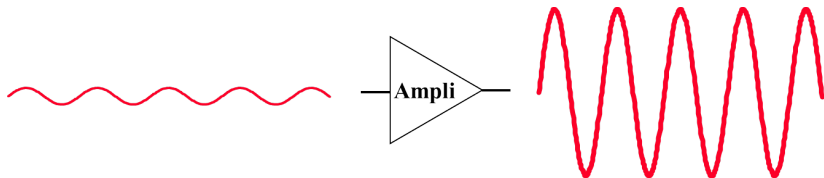

- ▶ Gain
- ▶ Noise
- ▶ Bandwidth
- ▶ Non-linearity
- ▶ Input range
- ▶ Output range

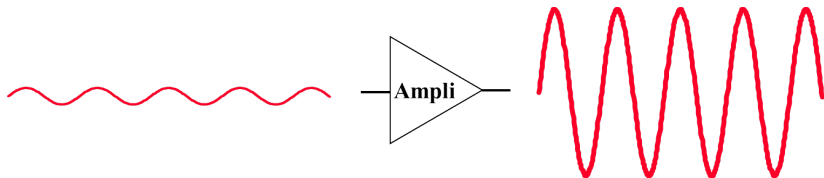

- ▶ Gain
- ▶ Noise
- ▶ Bandwidth
- ▶ Non-linearity
- ▶ Input range
- ▶ Output range
- ▶ Output impedance

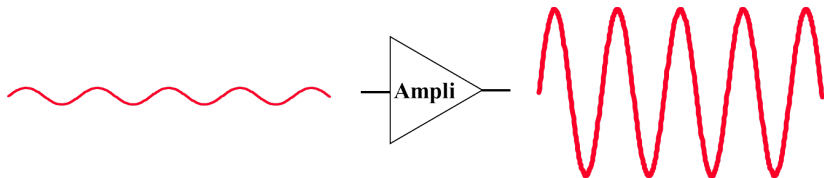

- ▶ Gain
- ▶ Noise
- ▶ Bandwidth
- ▶ Non-linearity
- ▶ Input range
- ▶ Output range
- ▶ Output impedance
- ▶ slew rate

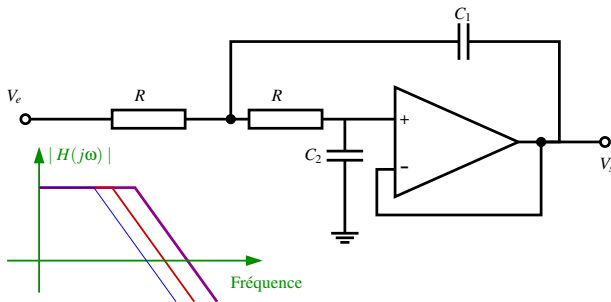

- ▶ Filtering type (Low pass, high pass, ...)
- ▶ Filter order
- ▶ In band ripple, out-of-band attenuation
- ▶ Group delay ($tg = -\frac{d\Phi}{d\omega}$)
- ▶ Approximations: Butterworth, Bessel, Tchebychev ...

Analog to Digital Converters

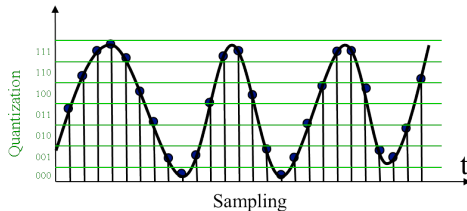
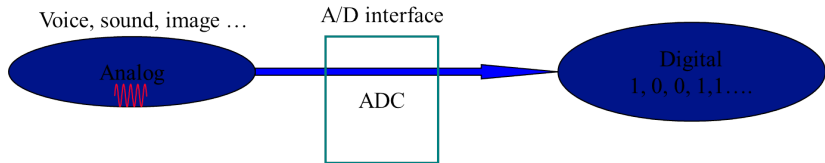

- Resolution/ Effective Number of bits

Analog to Digital Converters

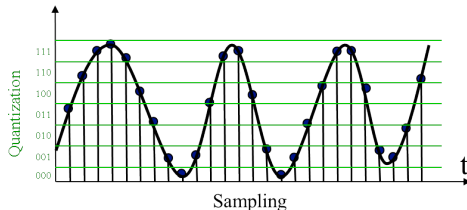
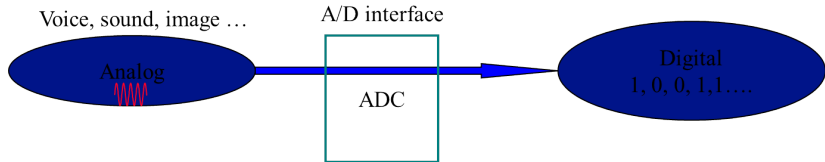

- ▶ Resolution/ Effective Number of bits
- ▶ Sampling Frequency

Analog to Digital Converters

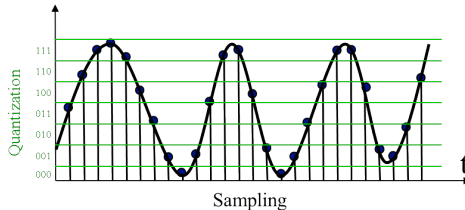
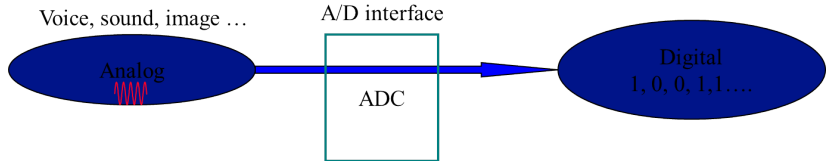

- ▶ Resolution/ Effective Number of bits
- ▶ Input range/Full scale
- ▶ Sampling Frequency

Analog to Digital Converters

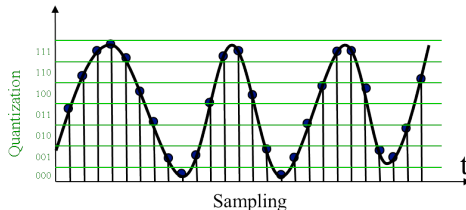
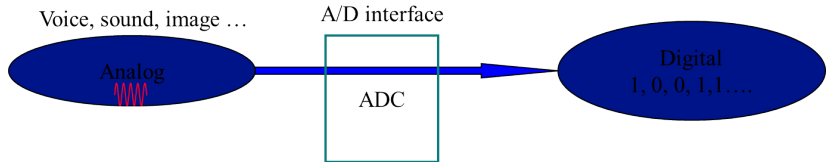

- ▶ Resolution/ Effective Number of bits
- ▶ Sampling Frequency
- ▶ Input range/Full scale
- ▶ Linearity

Analog to Digital Converters

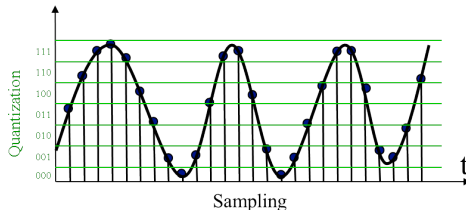
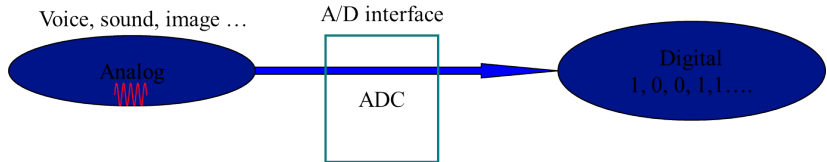

- ▶ Resolution/ Effective Number of bits
- ▶ Sampling Frequency
- ▶ Input range/Full scale
- ▶ Linearity
- ▶ Output interface

Interface with the real world in both directions

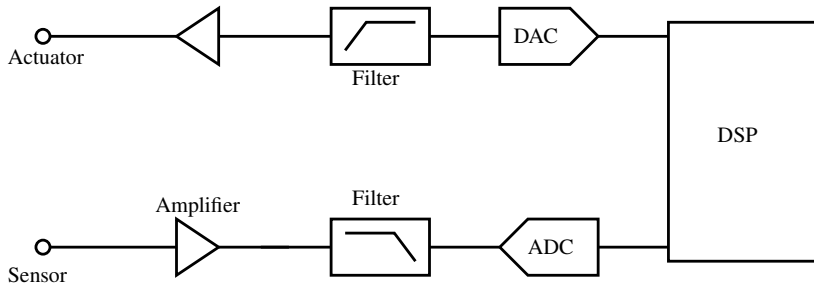

Embedded systems also need often to interact back with the real world

- ▶ Antenna
- ▶ Electrical/electronic switch
- ▶ Motor
- ▶ Ultra-sound sensor
- ▶ Controlled valve
- ▶ Screen
- ▶ Speaker
- ▶ Connected door lock
- ▶ Pulse generator
- ▶ ...

Embedded systems with remote centers/gateways

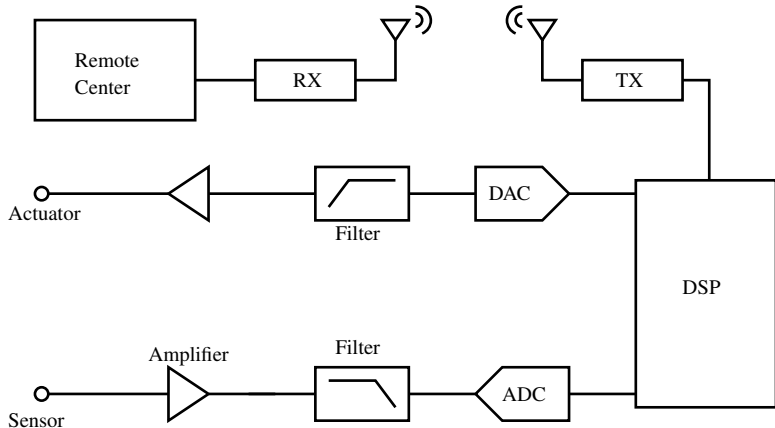

In some applications, information need to reported to a remote center



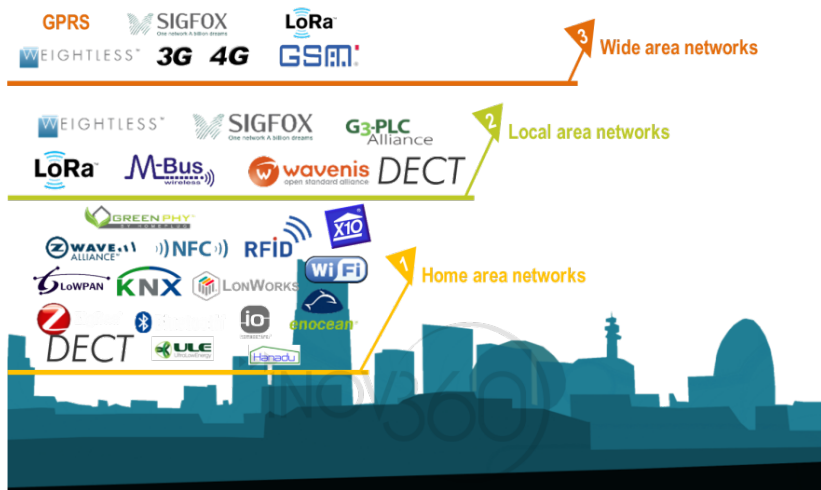



Transmission Protocols



Transmission Protocols comparison



The Internet of Things networking technology cheat sheet 1.0

Network:	Sigfox 	LoRa 	NB-IoT (Cat NB1) 	LTE-M (Cat M1) 	LTE Cat 0 	LTE Cat 1 
Type:	PLWAN	PLWAN	DSSS modulation	LTE (cellular)	LTE (cellular)	LTE (cellular)
Low Power:	+++++	++++	++++	+++	++	++
Throughput Kbit/s:	0,1	50	100	375	1000	10.000
Bandwidth:	Ultra-narrowband	Narrowband	Narrowband	Low	High	High
Latency:	1 – 30s	Based on profile	1.6 – 10s	10 – 15ms	Unknown	50 – 100ms
Standard:	Proprietary	Proprietary	3GPP Rel. 13	3GPP Rel. 13	3GPP Rel. 12	3GPP Rel. 8
Availability world-wide:	++	+++	++	++	+++++	++++
Spectrum:	Unlicensed ISM	Unlicensed ISM	Licensed LTE	Licensed LTE	Licensed LTE	Licensed LTE
Complexity:	Very low	Low	Very low	Low / medium	High	High
Coverage / range:	Medium / high	Medium / high	High	High	High	High
Battery life:	Very high	Very high / high	High	Medium / high	Low	Low
Gateway needed:	Yes	Yes	No, but optional	Optional	Optional	Optional
Signal penetration:	High	Medium / high	Medium / high	Medium / high	Low	Low
Security:	+++	+++	+++	+++++	++++	++++
Future proof:	+++	+++	+++++	+++++	+++	+++

See the accompanying blog series on basvankaam.com for more details on some of the abovementioned features/characteristics

Saturday, July 15, 2017 - Twitter @BasvanKaam



Constraints

- ▶ Cost \$\$\$\$\$
- ▶ Power consumption
- ▶ Security
- ▶ Dependability/Safety
- ▶ Miniaturization
- ▶ Mechanical vibrations
- ▶ Thermal variations
- ▶ Radiations
- ▶ Medical compatibility
- ▶ ...

Let's play

- ▶ Five Teams : Blue, black, green, red, orange
- ▶ Five applications :
 1. Assisted parking system
 2. Cardiac implant
 3. Irrigation system
 4. Microwave oven controller
 5. Aerspatial Observations

Phase 1

Every team has 30 sec. per application to list a critical constraint that is not already listed

Phase 2

Every team has 1 min. per application to rank the constraints from the most to the less constraining

Radiations: how does they impact the system

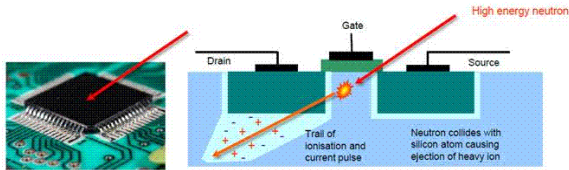

- ▶ Circuits are sensitive to radiations
 - Cosmic rays
 - Solar wind
 - Nuclear reactors and explosions
- ▶ Radiation can result in:
 - Short term dis-functionality
 - Loss of performance (Lower gain, higher leakage current ...)
 - Permanent damage of the radiated area

Radiations: Hardening techniques

► Physical hardening

- Shielding the package against radioactivity
- Use of radiation robust technology

► Hardening by design

- Take design margin to anticipate the loss of performance - analog circuits
- Triple modular redundancy for critical functions - digital circuits

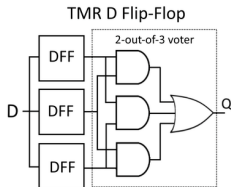

Temperature variations: how does they impact the system

When the temperature increases,

- ▶ the component (transistor, resistors) noise gets higher (approx. proportional to the temperature in Kelvin)
- ▶ the product lifetime gets lower
- ▶ the system becomes slower

DELAY VARIATION WITH TEMPERATURE FOR CIRCUITS OPERATING AT THE NOMINAL SUPPLY VOLTAGE ($V_{DD} = 1.0V$)
IN A 65NM CMOS TECHNOLOGY

65nm CMOS Technology	Temp (°C)	Inverter	NAND2	NAND4	NOR2	NOR4	XOR2	Domino AND2	Domino OR2	16-bit Brent Kung Adder
Average Delay (s)	25	1.54E-11	5.62E-11	8.65E-11	6.86E-11	1.35E-10	2.82E-11	3.73E-11	2.90E-11	6.33E-10
	125	2.08E-11	8.52E-11	1.32E-10	1.05E-10	2.05E-10	4.12E-11	5.55E-11	4.36E-11	9.79E-10
Delay Variation (%)		35.0	51.6	52.6	52.4	52.1	46.1	48.9	50.2	54.5

source: Kumar-ISCAS06

Temperature variations: solutions

- ▶ Employ a cooling/heating system to ensure that the embedded circuit is always inside the good temperature range

Temperature variations: solutions

- ▶ Employ a cooling/heating system to ensure that the embedded circuit is always inside the good temperature range
- ▶ Tackle the problem by design. For example, adjust the supply voltage or the biasing currents with the temperature variations

Temperature variations: solutions

- ▶ Employ a cooling/heating system to ensure that the embedded circuit is always inside the good temperature range
- ▶ Tackle the problem by design. For example, adjust the supply voltage or the biasing currents with the temperature variations
- ▶ Use a dedicated technology

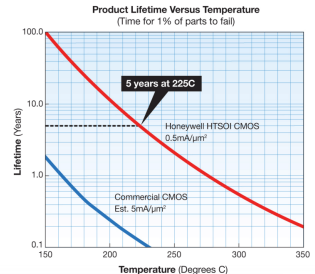
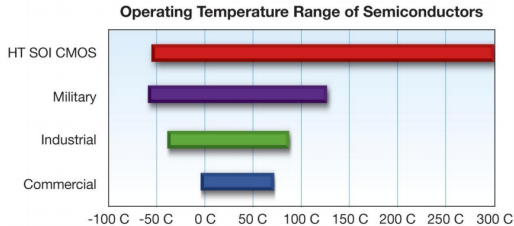

Battery life: S1 Reduce power consumption!

- ▶ Avoid over-sizing the system
 - Analog: *An amplifier with a Noise Figure of 3 dB will consume more than one with a NF of 6 dB*
 - Digital: *An FIR filter coded on 10 bits will consume twice less than an FIR filter coded on 20 bits*
- ▶ Use/design integrated solutions
 - *Interfacing integrated circuits burns a lot of power*
- ▶ Reduce the power supply
 - *Reducing power supply reduces power consumption but reduces the system speed*
- ▶ ...

Battery life: S2 Reduce energy consumption

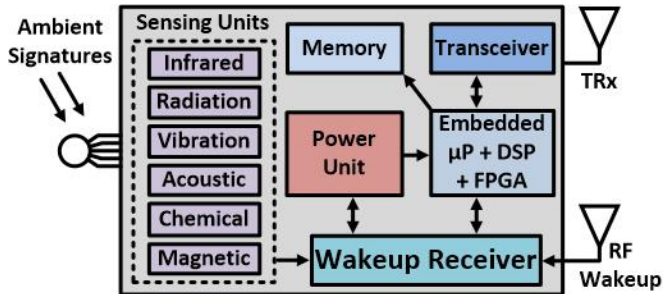

Wakeup receiver

A wakeup receiver is a low power radio whose purpose is to wake up the main radio when it detects a useful signal

Event/request driven system

Extending the battery life can be achieved by performing the measurements or the data exchange driven by a remote center

Battery life: S3 Better partitioning

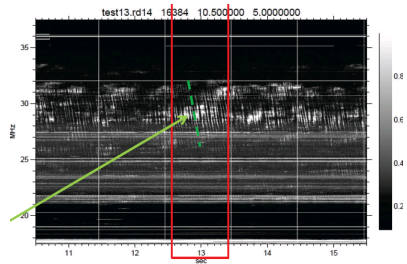
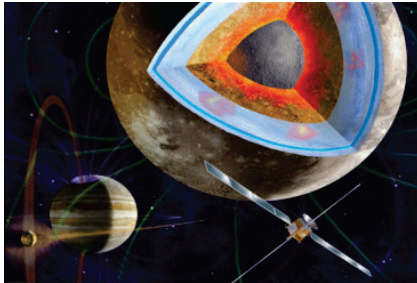

$F_s=80\text{MHz}$

The needed information is the slope of the frequency drift

S1: Extract the information on the spot

Extracting the needed information on the spot reduces the amount of information to be sent but increases the complexity of the processing

S2: Compress the signal

Compress the information at the sensor level and do the reconstruction on the remote server

Battery life: S4 Better management at DC level

- ▶ Use/design efficient DC-DC converters to generate the different power supplies for the system
- ▶ The battery specifications are typical values provided as design guidelines and are often neither tested nor guaranteed
- ▶ Turn off all unused circuits
- ▶ Don't oversize decoupling capacitors, the higher the capacitor the higher the leakage current

Battery life: S5 Harvest energy

Harvesting technology	Power density
Solar	
Solar cells (outdoors at noon)	15 mW/cm ²
Radio Frequency	
Dedicated source at short range	50 μ W/cm ²
Ambient RF	2 μ W/cm ²
Wind	
Small-scale turbine	83.3 μ W/cm ²
Vibration	
Piezoelectric (shoe inserts)	330 μ W/cm ²
Vibration (Magnetostrictive Metglas material)	606 μ W/cm ²



Wind energy harvesting

One drawback : space required is large
Small scale turbine, range : a few mW



Solar panels in 3 sizes with a coin to compare :
1.5 W – 10 W – 30 W

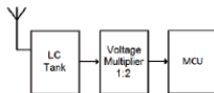

Standard RF energy harvester :
RF power density is lower than solar

T. Soyata et al., « RF Energy Harvesting for Embedded Systems :
A survey of Tradeoffs and Methodology

Conclusions

- ▶ Embedded systems need to interact with real worlds through efficient interfaces.
- ▶ Battery life is a critical aspect for most of embedded systems and could be improved by innovations at system level, component level and supply level.
- ▶ IoT, with 20 billion connected devices in 2020, will provide an important lever for embedded systems.
- ▶ Embedded systems are confronted for a diversity of constraints and each application should be optimized accordingly.

Huge opportunities

Libelium Smart World

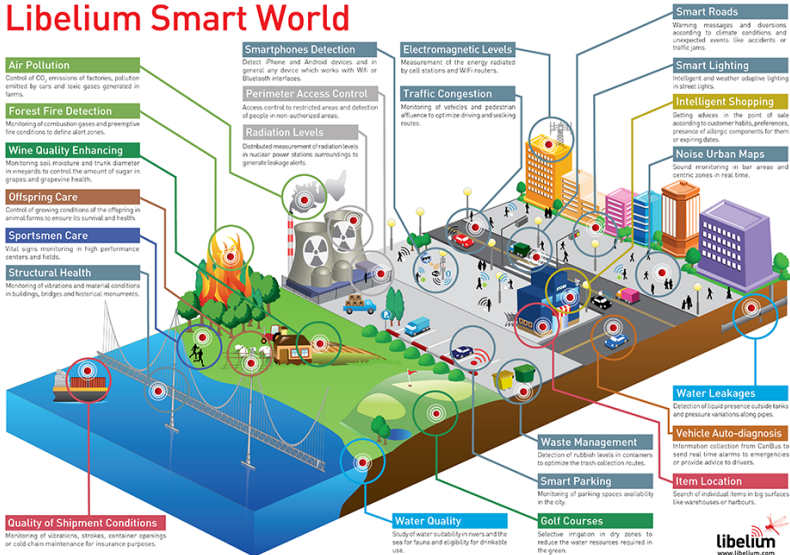

libelium
www.libelium.com

TELECOM
ParisTech

Course organization

- ▶ General
 - Introduction - 1.5 hour - Chadi Jabbour
 - Noise and perturbations - 1.5 hour - Patricia Desgreys
 - SE in automotive - 3.5 hours - Abdelaziz Elaabid (PSA)
- ▶ Analog to digital converters
 - Course - 2 hours - Patricia Desgreys
 - TD - 1.5 hour - Patricia Desgreys
 - Lab - 3 hours - Chadi Jabbour (20 %)
- ▶ Digital Filtering
 - Course - 1.5 hour - Chadi Jabbour
 - TD - 1.5 hour - Chadi Jabbour
 - MiniLab - 1.5 hour - Chadi Jabbour (10 %)
- ▶ Low power embedded systems
 - Low power CMOS design - 1.5 hour - Chadi
 - Energy Harvesting - 2 hours - Germain Pham
 - Analog to information converters - 2 hours - Paul Chollet
- ▶ Final exam (70%)

This is the end

Thank you for your attention

Questions ?

Site Web

<https://perso.telecom-paristech.fr/jabbour/enseignement/SE208/>